

**外形图 (DIMENSIONS) unit=mm**

引出线定义:

功率线	相序
50mm <sup>2</sup>	U
50mm <sup>2</sup>	V
50mm <sup>2</sup>	W

编码器信号线航插定义  
YD18J7Z

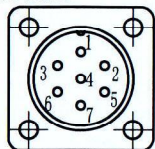

针脚号	功能
1	PE
2	+5V
3	GND
4	SD+
5	SD-
6	电池+
7	电池-

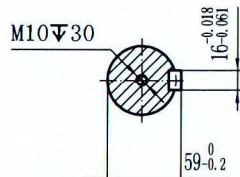

备注: 16×10×65键压入键槽中

3× SC50-10, 50mm<sup>2</sup>  
U/V/W标识套管  
连接器端部至机座长1000~1100mm

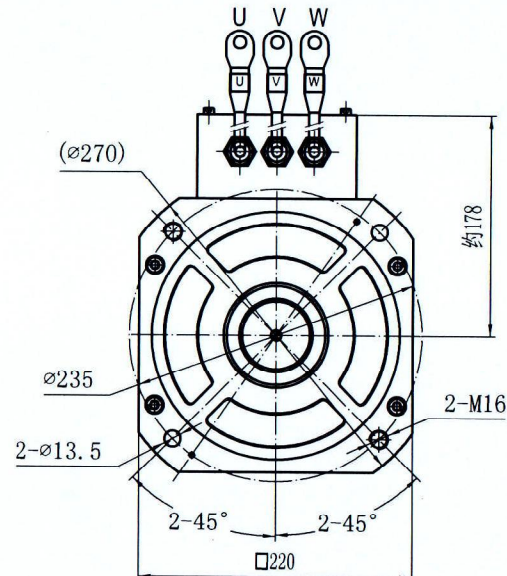
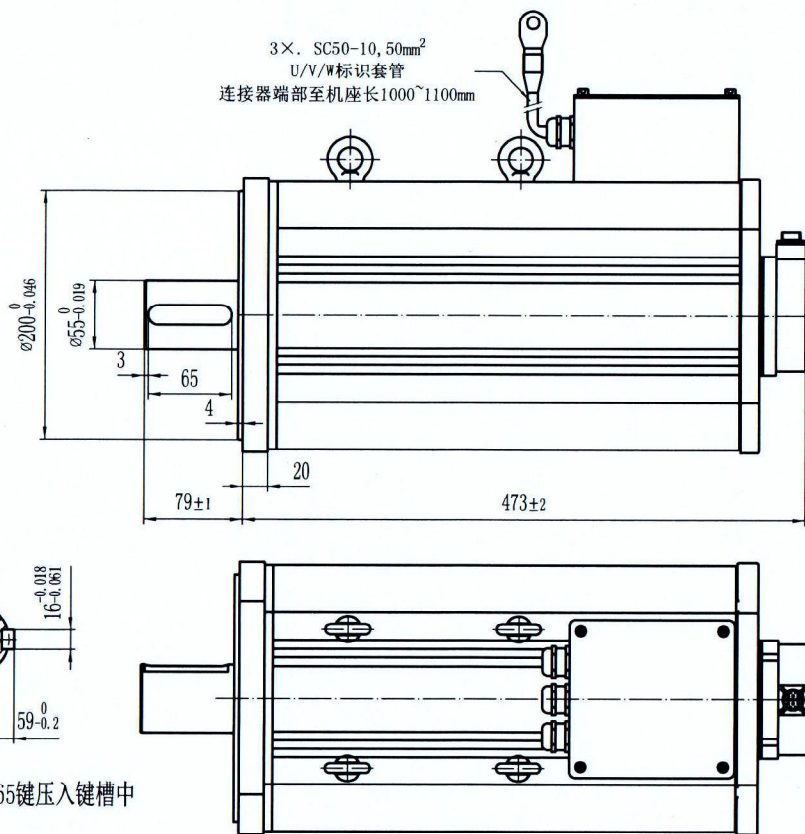

**规格 Specifications**

额定功率 Rated Power (kW)	20	线电阻 Line-Line Resistance (mΩ)	TBD ± 10%
额定电压 Rated Voltage (V)	96VDC	线电感 Line-Line Inductance (mH)	TBD ± 20%
额定电流 Rated Current (A)	236	电气常数 Electrical Time Constant (ms)	TBD
额定转速 Rated Speed (rpm)	1500	接线方式 Winding Connection	Y
额定力矩 Rated Torque (N*m)	127	绝缘等级 Insulation Class	F
峰值力矩 Peak Torque (N*m)	254	防护等级 Safety Class	IP65 (轴、接线盒除外)
反电势 Voltage Constant (V/krpm)	33 ± 10%	极对数 Pole-pairs	5
力矩系数 Torque Coefficient (N*m/A)	0.55	编码器型号 Encoder Type	SRM46-M16S17BIT-SYH-C-5V
转子惯量 Rotor Inertia (Kg.m) <sup>2</sup>			

CONFIRMED&ACCEPTED BY CUTOMER (客户确认&接受)				品名			
COMPANY CHOP&SIGNATURE (盖章&签名)				电机规格书			
一般公差 TOLERANCE ±0.3/±3°				版本	年月日	变更番号	变更内容
制图/DRAWN		比例 SCALE	1:1	物料号		设计	备注 NOTE
设计/DESIGNED		单位 UNIT	mm	型号	M220AIS473-96-C236015-5-B1	REV.	A
审核/CHECKED		上海四横电机制造有限公司				页 SHEET	1/1
承认/APPROVED							